

IPPC 1640P

15.6" TFT WXGA 16:9 Heavy Industrial Panel PC
with Intel® Celeron® Quad Core Processor J1900, up to 2.42GHz,
Multi-Touch Screen, 4GB DDR3L, 3 x USB, 2 x COM and Fieldbus Port



Main Features

- Intel® Celeron® quad core processor J1900, up to 2.42GHz, 2M L2 Cache
- Metal housing with robust aluminum front zero bezel for harsh environment
- 10 points P-Cap multi-touch with zero bezel flush front design
- Dual GbE/2nd display-VGA/ Line-out/PS2 KB/MS
- USB x 3/2 x mini-PCIe sockets/1 x CFast/2 x RS232/422/485
- DDR3L 4GB/2.5" HDD bracket
- IP66 compliant front panel
- Support fieldbus module, JMobile HMI and CODESYS SoftLogic (optional)
- Mounting support: panel/wall/stand/VESA 100mm x 100mm
- Wide range power input: 12~30VDC

Product Overview

The 15.6" fanless panel PC IPPC 1640P incorporating an industrial motherboard is intended for versatile industrial applications. The panel PC has a touch screen LED backlight LCD panel with 1366x768 (HD; WXGA) resolution. The front panel which adopts flush design and complies with IP66 standard makes it the perfect fit in industrial applications.

The IPPC 1640P supports WWAN/WLAN expansion and others via dual Gigabit Ethernet connectors, two Mini-PCIe slots and one SIM card holder. With support for wide power input of 12~30VDC, IPPC 1640P can gain a strong foothold in industrial field and machine devices. In addition, IPPC 1640P can hook 2nd display via a VGA port for dual independent display. IPPC 1640P has two isolated RS232/422/485 ports and optional fieldbus ports.

Specifications

Panel

- LED size: 15.6", 16:9
- Resolution: WXGA 1366x768
- Luminance: 300cd/m²
- Contrast ratio: 500
- LCD color: 16.7M
- Viewing angle: 80(U), 80(D), 85(L), 85(R)
- Backlight: LED

Touch

- Ten points P-Cap (Projected Capacitive Touch)
- Touch light transmission: 87%
- Anti-scratch surface: 7H hardness
- Touch interface: USB
- Windows 8 compliance

System

- CPU: On-board Intel® Celeron® quad core processor J1900, up to 2.42GHz, 2M L2 Cache
- BIOS: AMI BIOS
- System memory: 2 x 204-pin DDR3L SO-DIMM socket, 4GB DDR3L (Default), support up to 8GB DDR3L-1066/1333, Non-ECC and Un-buffered

- Storage Device:
 - 1 x external locked CFast socket
 - 1 x hard drive bay: optional 1 x 2.5" SATA HDD or 1 x SATA DOM
- Watchdog timer: watchdog timeout can be programmable by software from 1 second to 255 seconds and from 1 minute to 255 minutes (tolerance 15% under room temperature 25°C)
- H/W status monitor: monitoring system temperature, and voltage
- Expansion: 2x Mini-PCIe sockets (support optional Wi-Fi, 3.5G module or fieldbus card)
- Panel backlight control button: increase brightness/decrease brightness/backlight on/off
- Front logo LED indicator to show operating status

Rear I/O

- Ethernet: 2 x RJ45
- 2nd display VGA port: 1 x DB15
- Audio port: 1x Line out
- USB: 2 x USB 2.0, 1 x USB 3.0
- 2-pin Remote Power on/off switch
- Power switch
- Reset button
- COM #1: RS232/422/485 w/ 2.5kv isolated
- COM #2: RS232/422/485 w/ 2.5kv isolated
- Fieldbus: (protocol interface optional)

Dimension Drawing

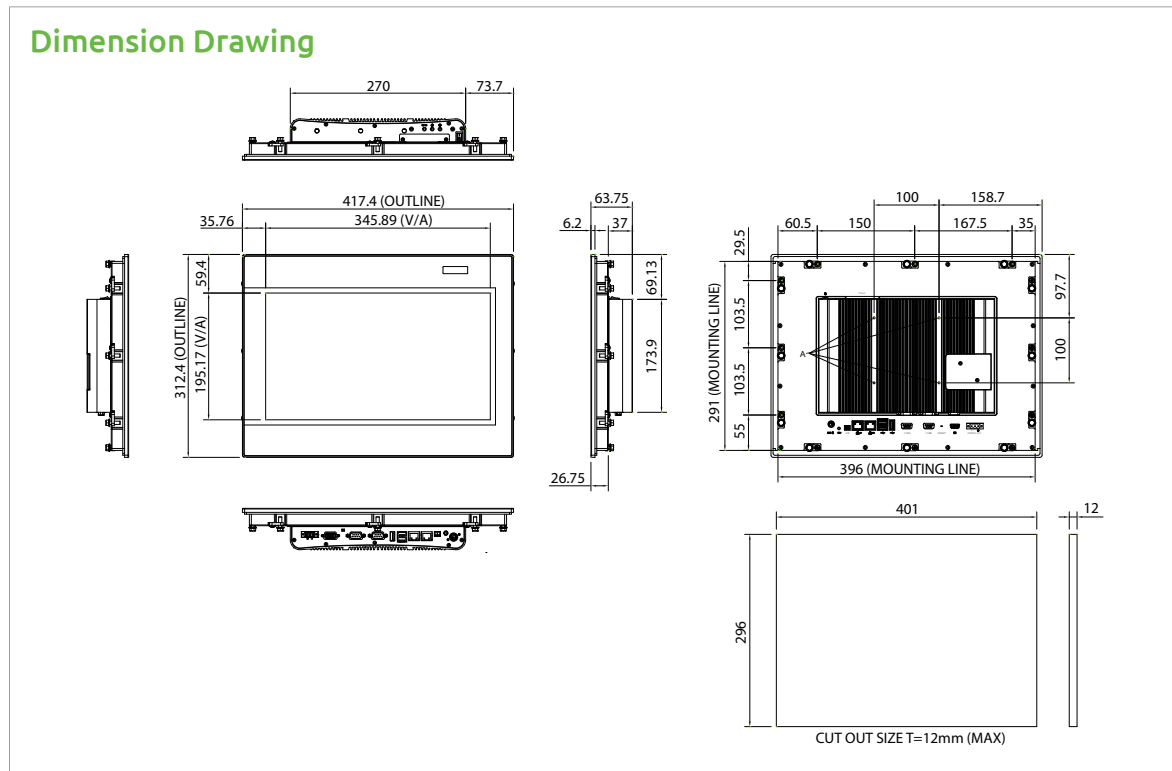

Model	Protocol	Connector
FBI90E-PNM	ProfiNET master	Dual RJ-45
FBI90E-EP	Ethernet/IP master	
FBI90E-ECM	EtherCAT master	DB9
FBI90E-PBM	Profibus master	
FBI90E-DNM	DeviceNet master	

Audio

- HD codec: Realtek ALC886-GR
- Audio interface: Line-out/Line-in(optional)/Mic-in(optional) audio Jack

Ethernet

- LAN chip: dual Intel® I210AT Gigabit LAN
- Ethernet interface: 10/100/1000 based-Tx Ethernet compatible

Mechanical & Environment

- Color: Pantone 425C/RAL 70 24 front bezel
- IP protection: IP66 front
- Mounting: panel/wall/stand/VESA 100mm x 100mm
- System with panel mounting kit w/o panel mounting hole
- Power input: 12~30VDC
- Power adapter: optional AC to DC power adapter (+12V, 60W)
- Vibration:
 - IEC 68 2-64 (w/ HDD)
 - 1Grms @ sine, 5~500Hz, 1hr/axis (HDD operating)
 - 2Grms @ sine, 5~500Hz, 1hr/axis (CFast operating)
 - 2.2Grms @ random condition, 5~500Hz, 0.5hr/axis (non-operating)
- Shock:
 - IEC 68 2-27
 - HDD: 20G@wall mount, half sine, 11ms
- Operating temperature: -10°C to 60°C
- Storage temperature: -20°C to 75°C
- Operating humidity: 10%~90% relative humidity, non-condensing
- Dimension: 417.4 x 312.4 x 63.75mm
- Weight: 6.4Kg

Certifications

- CE (including EN61000-6-2/EN61000-6-4)
- FCC class A

OS Support Lists

- Windows 8 32bit/64bit
- Windows 7 32bit/64bit
- WinCE 7.0

Ordering Information

Barebone

- **IPPC 1640P (P/N: 10I11640P00X0)**
15.6" WXGA LED backlight touch panel PC, Intel® Celeron® quad core processor J1900, up to 2.42GHz, touch screen, 4GB DDR3L, 2 x RS232/422/485 and brightness adjustment buttons, optional fieldbus module

Options

- **12V, 60W AC/DC power adapter w/ o power cord (P/N: 7400060019X00)**
- **PROFINET master interface module: FBI90E-PNM for APPC (P/N: 88IA1932T00X0)**
- **EtherNet/IP master interface module: FBI90E-EP for APPC (P/N: 88IA1932T01X0)**
- **EtherCAT master interface module: FBI90E-ECM for APPC (P/N: 88IA1932T02X0)**
- **PROFIBUS master interface module: FBI90E-PBM for APPC (P/N: 88IA1932T03X0)**
- **DeviceNet master interface module: FBI90E-DNM for APPC (P/N: 88IA1932T04X0)**